



Air cooled chillers

with propeller fans **ciatcooler**

LC

Cooling capacity : 260 to 500 kW

Reciprocating compressors
CIAT direct expansion shell and tubes evaporator
Option for hydraulic pack "Plug and Cool"

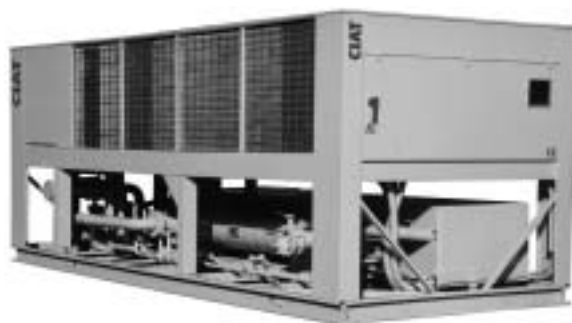

PROPELLER
FANS



Cooling only



Hydraulic pack



Heating recovery



USE

CIATCOOLER LC

Air cooled water chillers **CIATCOOLER LC** with CIAT fan coil units, air handling units and chilled water cassette allow to answer to any air conditioning applications and industrial process.

These compact and packaged units are designed for outdoor installation with high external air temperature operation.

CIATCOOLER LCT

These units are equipped with recovery water condenser for hot water heating supply.

This design is very interesting for chillers running all the year and allows to save energy.

CIATCOOLER LCH

Air cooled water chillers **CIATCOOLER LCH** are designed with integrated hydraulic equipment (buffer, tank, expansion vessel, hydraulic pump, valves, ...).

This design allows an easy installation, a space saving and a time saving for installation.

A large selection of pumps is available for any head pressure.

RANGE

CIATCOOLER LC - LCT - LCH

8 models : 1203Z - 1400Z - 1600Z - 1803Z - 1804Z - 2000Z - 2200Z - 2400Z

■ CONFIGURATION

a - **STANDARD** version - ventilation 905 rpm

b - **LOW NOISE** version - ventilation 715 rpm+ compressors phonic insulation

■ Unit conforms norms :
EN60-204 – EN 378-2

■ Unit conforms directives :

– 98/37 CEE

– CEM (89/336 CEE) modified 92/31 CEE - 93/68 CEE

– Basse tension (73/23 CEE) modified 93/68 CEE

– DESP 97/23/CE

Group 3 models LC-LCH 1203Z to 2400Z / LCT 1203Z

Group 4 models LCT 1400Z to 2400Z

DESCRIPTION

CIATCOOLER LC

■ Accessible hermetic compressors

- Reciprocating.
- Pressure lubrication controlled by a differential pressostat.
- Integral electronic protection of motor.
- Mounting on antivibration mounts.

■ Shell and tube evaporator

- Direct expansion.
- Copper tubes bundle, steel shell.
- Corrosion resistant baffles.
- Thermal insulation with polyurethane foam.

■ Air-cooled condenser

- "U" condensing coils, copper tubes, aluminium fins.
- propeller fans, direct drive **930 or 730 rpm**.

■ Accessories

- Filter dryers.
- Liquid sight glasses.
- Solenoid valves on liquid line.
- Thermostatic expansion valves.

■ Control and safety

- High and low pressure safety pressostats.
- Oil differential pressostats.
- Chilled water and anti-freeze sensors.
- Evaporator water flow switch.

■ Electrical panel

- Electrical supply 400 V - 3 ph - 50 Hz + Earth ($\pm 5\%$)
- Main safety switch with external handle.
- Remote control transformer.
- Power and control circuits protection.
- Contactors and circuit breakers for compressors and fan motors.

■ MRS1.4 microprocessor electronic module ensuring the following functions :

- Chilled water temperature control.
- Operating parameters control.
- Faults diagnosis.
- Counting and balancing of compressors running times.
- Chilled water temperature display.
- RS485 output for bus connection.

■ Frame and casing

Frame and casing in galvanised steel sheet.

CIATCOOLER LCH

■ Identical to **CIATCOOLER LC** but with a complete integrated hydraulic equipment.

- 1 buffer tank with thermal insulation.
- 1 centrifugal single or twin pump.
- 1 expansion vessel.
- 1 automatic air vent.
- 1 safety valve (4 bars).
- 1 filling hole with valves.
- 1 draining hole with valve.
- 1 set of shut off valves.
- pumps contactors and protections.

CIATCOOLER LCT

Identical to **CIATCOOLER LC** but with recovery water condensers.

- 1 shell and tubes water cooled condenser on each refrigerant circuit with polyurethane foam insulation and antifreeze protection.
- 1 refrigerant liquid receiver per circuit

OPTIONS

■ Low Noise version

■ Anti-vibration equipment

- Anti-vibration mounts
- Evaporator flexible sleeves

■ Pressure gauges

- 1 HP gauge per circuit
- 1 LP gauge per circuit
- 1 oil pressure manometer per compressor

■ Electrical supply

- 230V - 3 ph - 50 Hz + earth

■ Part winding or start / delta starting

■ Compressors phonic insulation

■ 1 side polyurethane painting

■ Polyurethane coating on fins or BLYGOLD POLUAL treatment on coil

■ Remote control box

■ Free contacts relay card kit

■ Condenser coil protection grid

■ Low temperature glycol water (LC-LCT)

■ Wiring numbering for electrical panel

■ Compressor suction isolating valve

■ Condenser flexible sleeves (LCT)

■ Antifreeze protection (LC - LCH)

■ All year round operation (LC - LCH)

■ Brazed plates desuperheaters (LC - LCH) (1 on each refrigerant circuit)

■ Glycol water expansion vessel (LCH)

TECHNICAL CHARACTERISTICS

LC - LCT - LCH		1203Z	1400Z	1600Z	1803Z	1804Z	2000Z	2200Z	2400Z		
Standard version	Cooling capacity (1)	kW	259	290	326	357	374	403	450	483	
	Absorbed power (2)	kW	107	117	131	147	153	163	183	199	
Low Noise version	Cooling capacity (1)	kW	250	281	318	348	361	392	435	470	
	Absorbed power (2)	kW	104	114	127	144	150	160	179	195	
Recovery version	Cooling capacity (3)	kW	260	287	340	357	379	407	459	494	
	Compressor absorbed power	kW	94	103	123	130	135	145	160	175	
Compressor	Type	Reciprocating									
	Number	3				4					
	Rotation speed	rpm	1450								
	R407C refrigerant charge LC - LCH	kg	38+18	50+20	45+23	47+23	45+35	2x47	57+53	2x60	
	R407C refrigerant charge LCT		80+50	140+50	80+110	120+80	105+50	2x150	150+180	2x200	
	Capacity control	%	100-66 33-0	100-65 35-0	100-69 31-0	100-66 33-0	100-72 50-23-0	100-75 50-25-0	100-72 50-23-0	100-75 50-25-0	
	Type of oil for R407C	MOBIL EAL ARTIC 22 CC									
	Oil charge for compressor	liters	3 x 7.4	2 x 7.4 + 7.7	3 x 7.7	4 x 7.4	2 x 7.7 + 2 x 7.4	4 x 7.7			
	Evaporator	Type	Direct expansion shell and tubes								
Number		1									
Water capacity		liters	94			117		156			
Hydraulic connection		FLANGES									
Maximum pressure on water side		bar	10								
Maximum water flow		m ³ /h	71			97		114			
Air cooled condenser		Fans	Direct drive propeller type - 760 mm diameter								
	Number of fans	6		8			10				
	Rotation speed	rpm	930 rpm STANDARD version								
	Air flow	m ³ /h	106700	105600	146400	145000	143200	140800	179500	176000	
	Motor unit power	kW	1.5								
	Rotation speed	rpm	730 rpm LOW NOISE version								
	Air flow	m ³ /h	84300	83300	115600	114500	113000	111000	141700	139000	
	Motor unit power	kW	0.75								
Shell and tubes water condenser LCT	Number	2									
	Water capacity	liters	19+39	19+39	25+39	25+58	2x39	2x39	2x58	2x58	
	Maximum water flow	m ³ /h	102		114	143	140		198		
Hydraulic equipment LCH	Tank capacity	liters	1000		1400						
	Pure water expansion vessel	liters	50		80						
	Glycol water expansion vessel	liters	160 (2x80)								
Standard version	Lw / Lp (4)	dB(A)	92/60		93/61		92/60	93/61	94/61		
Low Noise version	Lw / Lp (4)	dB(A)	87/55		88/56		87/55	88/56	89/56		

(1) Cooling capacity for 12 / 7°C chilled water and +35°C external air temperature

(2) Compressors + fans absorbed power

(3) Cooling capacity for 12 / 7°C chilled water and +45°C hot water outlet temperature

(4) Lw : Global sound power level

Lp : Global sound pressure level at 10 meters, in free field, following ISO 3744 regulation



Air cooled chillers with propeller fans

ciatcooler



PERFORMANCES

CIATCOOLER LC - LCT - LCH (930 rpm fans)

LC LCT LCH	Evaporator water outlet temperature °C	CONDENSER AIR INLET TEMPERATURE °C								
		28		32		36		40		
		Pf kW	Pa kW	Pf kW	Pa kW	Pf kW	Pa kW	Pf kW	Pa kW	
1203Z	Glycol water*	-6	169	71	157	73	145	75	145	80
		-4	182	73	171	76	158	78	145	80
	Pure water	2	236	83	221	86	205	89	190	91
		5	267	88	252	92	236	95	220	98
		7	286	92	270	95	254	99	237	101
		12	339	100	320	104	300	108		
1400Z	Glycol water*	-6	187	78	175	81	162	84	166	90
		-4	202	81	190	84	178	87	166	90
	Pure water	2	261	91	246	95	232	98	217	102
		5	297	96	282	101	265	105	250	108
		7	319	100	302	104	286	108	270	112
		12	378	109	359	114	340	118		
1600Z	Glycol water*	-6	208	86	195	89	183	93	188	100
		-4	225	89	213	93	200	96	188	100
	Pure water	2	291	100	276	104	261	109	246	113
		5	332	106	315	111	299	116	282	120
		7	358	110	339	115	321	120	304	124
		12	424	120	404	126	384	131	363	136
1803Z	Glycol water*	-6	230	97	218	101	204	105	210	112
		-4	250	100	236	105	223	109	210	112
	Pure water	2	320	113	303	118	287	123	270	127
		5	364	121	346	126	328	131	311	136
		7	391	125	371	131	352	136	334	141
		12	464	138	441	144	419	150		
1804Z	Glycol water*	-6	243	102	228	106	212	109	216	117
		-4	263	105	247	110	231	114	216	117
	Pure water	2	338	119	318	124	298	128	277	132
		5	384	126	364	132	342	137	320	142
		7	413	131	391	137	368	142	345	147
		12	488	143	463	150	437	155		
2000Z	Glycol water*	-6	258	110	242	114	226	118	232	127
		-4	280	113	264	118	248	123	232	127
	Pure water	2	361	127	341	133	321	138	302	143
		5	411	135	390	141	368	147	347	153
		7	442	139	419	146	397	152	374	158
		12	525	152	499	159	472	166		
2200Z	Glycol water*	-6	282	121	264	126	247	130	254	140
		-4	305	125	288	131	270	136	254	140
	Pure water	2	400	141	377	147	357	153	334	158
		5	460	150	435	157	410	164	388	170
		7	493	156	467	163	443	170	418	176
		12	584	171	556	179	526	186		
2400Z	Glycol water*	-6	307	132	287	137	270	142	278	153
		-4	332	137	313	142	296	148	278	153
	Pure water	2	434	154	411	161	388	167	365	173
		5	496	164	470	172	445	179	420	185
		7	533	171	505	178	476	186	453	192
		12	629	187	596	196	568	204		

Pf : Cooling capacity valid for a ΔT according to operation limits

Pa : Compressor absorbed power

* Glycol water is necessary

Option low temperature necessary (only available for LC-LCT versions)

PROPELLER
FANS

R407C

CIAT Air cooled chillers with propeller fans

ciatcooler **LC**

PERFORMANCES

CIATCOOLER LCT

PROPELLER
FANS

R407C

LCT	Evaporator water outlet temperature °C	CONDENSER WATER OUTLET TEMPERATURE °C						
		40			45			
		Pf kW	Pa kW	Pc kW	Pf kW	Pa kW	Pc kW	
1203Z	Glycol water*	-4	167	74	241	151	77	228
		2	221	82	303	203	86	289
	Pure water	5	260	87	347	240	91	331
		7	283	89	372	260	94	354
1400Z	Glycol water*	-4	181	82	263	165	86	251
		2	241	90	331	222	95	317
	Pure water	5	285	95	380	263	100	363
		7	307	97	404	287	103	390
1600Z	Glycol water*	-4	202	92	294	187	97	284
		2	271	101	372	253	107	360
	Pure water	5	336	113	449	312	120	432
		7	364	116	480	340	123	463
1803Z	Glycol water*	-4	225	103	328	210	108	318
		2	301	113	414	280	120	400
	Pure water	5	351	119	470	327	126	453
		7	382	123	505	357	130	487
1804Z	Glycol water*	-4	240	108	348	221	113	334
		2	322	119	441	295	124	419
	Pure water	5	376	125	501	349	132	481
		7	408	128	536	379	135	514
2000Z	Glycol water*	-4	256	116	372	236	122	358
		2	342	127	469	317	134	451
	Pure water	5	401	133	534	373	141	514
		7	436	136	572	407	145	552
2200Z	Glycol water*	-4	284	128	412	266	134	400
		2	386	141	527	359	148	507
	Pure water	5	450	147	597	420	156	576
		7	489	151	640	459	160	619
2400Z	Glycol water*	-4	311	139	450	289	145	434
		2	414	153	567	388	162	550
	Pure water	5	487	161	648	452	170	622
		7	527	165	692	494	175	669
		12	643	176	819	602	188	790

Pf : Cooling capacity valid for a ΔT according to operation limits

Pa : Compressor absorbed power

Pc : Cooling capacity valid for a ΔT according to operation limits

* Glycol water is necessary

Option low temperature necessary (only available for LC-LCT versions)

OPERATING LIMITS IN FULL LOAD

CIATCOOLER	LC - LCH	LCT
Air cooled condenser • Mini. °C • Maxi °C	+ 12* 40	- 15 40
Water cooled condenser • ΔT mini. °C • ΔT maxi °C • Max. hot water outlet °C	NO	5 10 50
Water cooled condenser • ΔT mini. °C • ΔT maxi. °C	Depending of the chilled water outlet See graph below	

* +12 °C standard version
-15 °C with all year around operation

EVAPORATOR LIMITS

The curves below represent the minimum and maximum allowable temperature difference of the glycol or chilled water depending upon the outlet temperature.

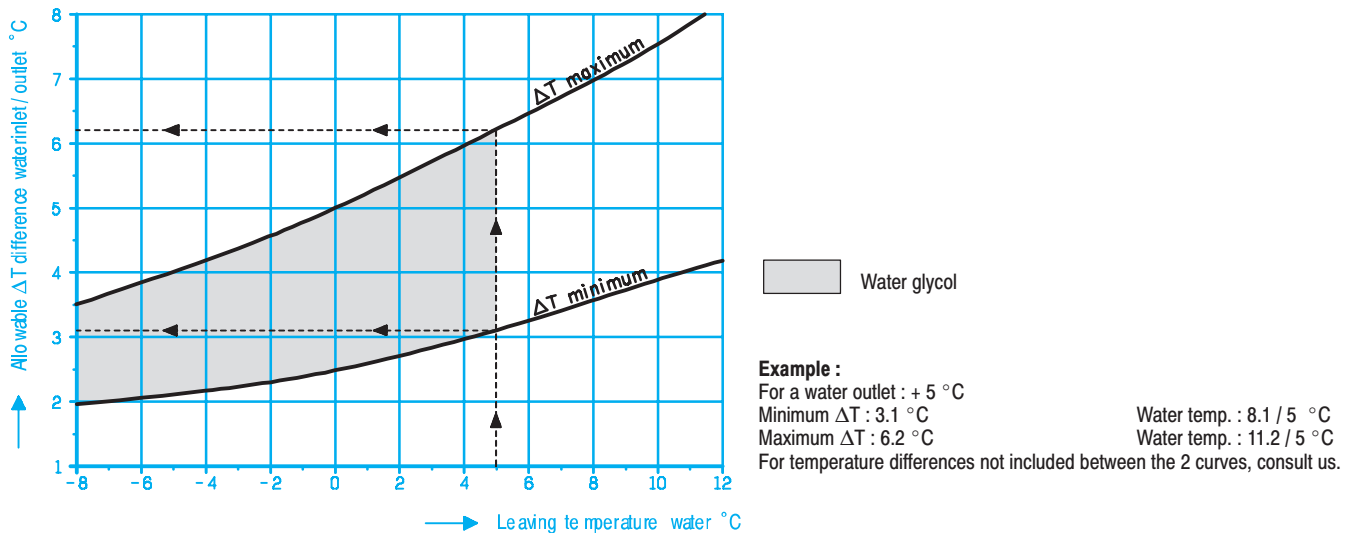

WATER GLYCOL COEFFICIENTS

- 30 % concentration of glycol weight
- Freezing point of the solution : -16 °C.

CORRECTION		POSITIVE TEMPERATURE		NEGATIVE TEMPERATURE	
		K	Calculation	K	Calculation
Evaporator	Cooling capacity	0.98	$P_{fc} = P_f \times 0.98$	1.00	See selection table
	Chilled water flow*	1.05	$Q_c = \frac{P_{fc} \times 0.86}{\Delta T} \times 1.05$	1.10	$Q_c = \frac{P_{fc} \times 0.86}{\Delta T} \times 1.10$
	Pressure drop	1.15	$\Delta P_c = \Delta P \times 1.15$	1.30	$\Delta P_c = \Delta P \times 1.30$
	Average temperature °C		12 / 7		See table
Condenser	Cooling capacity	0.97	$P_{fc} = P_f \times 0.97$		
	Chilled water flow*	1.05	$Q_c = \frac{(P_{fc} + P_a) \times 0.86}{\Delta T} \times 1.05$		
	Pressure drop	1.10	$\Delta P_c = \Delta P \times 1.10$		
	Average temperature °C		35 / 40		

* With the correct cooling capacity and compressor absorbed power, calculate the recovered heating capacity and hot water flow.

CIAT Air cooled chillers with propeller fans

ciatcooler **LC**

VERSION WITH HYDRAULIC EQUIPMENT LCH SERIES

The PLUG AND COOL solution with CIATCOOLER LCH

The hydraulic equipment is designed with all the hydraulic circuit components required for a correct operation of the unit :

- Buffer tank.
- Expansion vessel.
- Water flow switch.
- Pressure gauges with shut off valve.
- Antifreeze protection of hydraulic circuit (optional).
- Draining valve.
- Automatic and manual air vent.
- Safety valve.
- Filling hole with valves.
- **Large choice of single or twin pumps (1).**

Control of the assembly.

Easy to install, all the components of hydraulic equipment are optimised, fitted and tested in the factory.

With the hydraulic equipment, **CIATCOOLER LCH** is ready to run and this is very easy to do air conditioning or industrial process.

(1) Pumps are designed to work with closed water circuit. For any others applications, consult us (open water circuit, high head pressure, etc.).

HYDRAULIC CIRCUIT

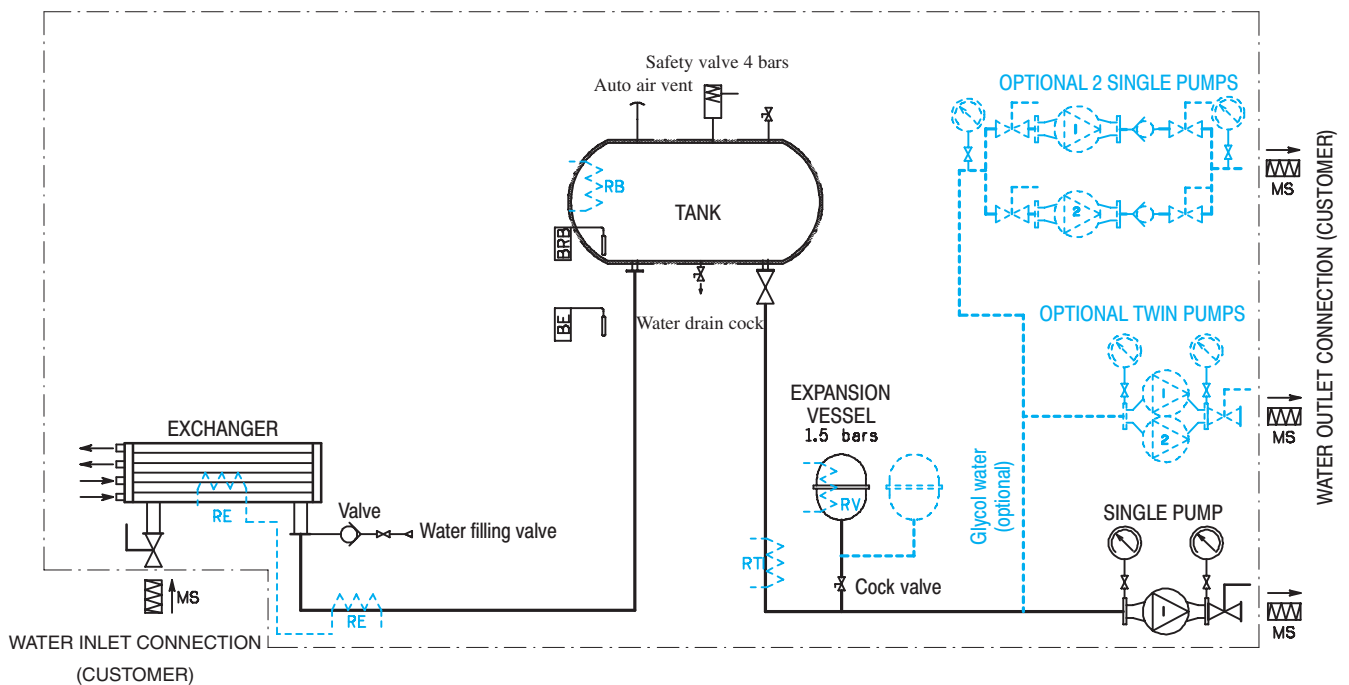

Options :

- Piping flexible sleeves (MS)
- Antifreeze protection (RE - RB - RT - RV)
- Twin pumps

HYDRAULIC CHARACTERISTICS

■ Hydraulic equipment + evaporator
LCH water pressure drop

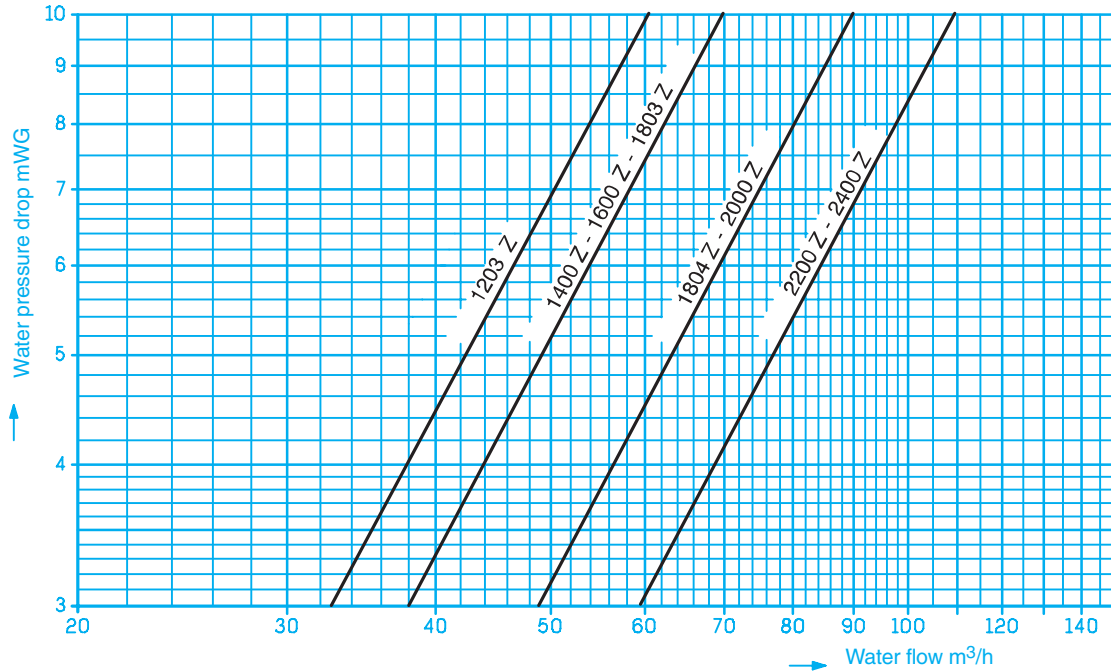

PROPELLER
FANS

■ Pumps selection

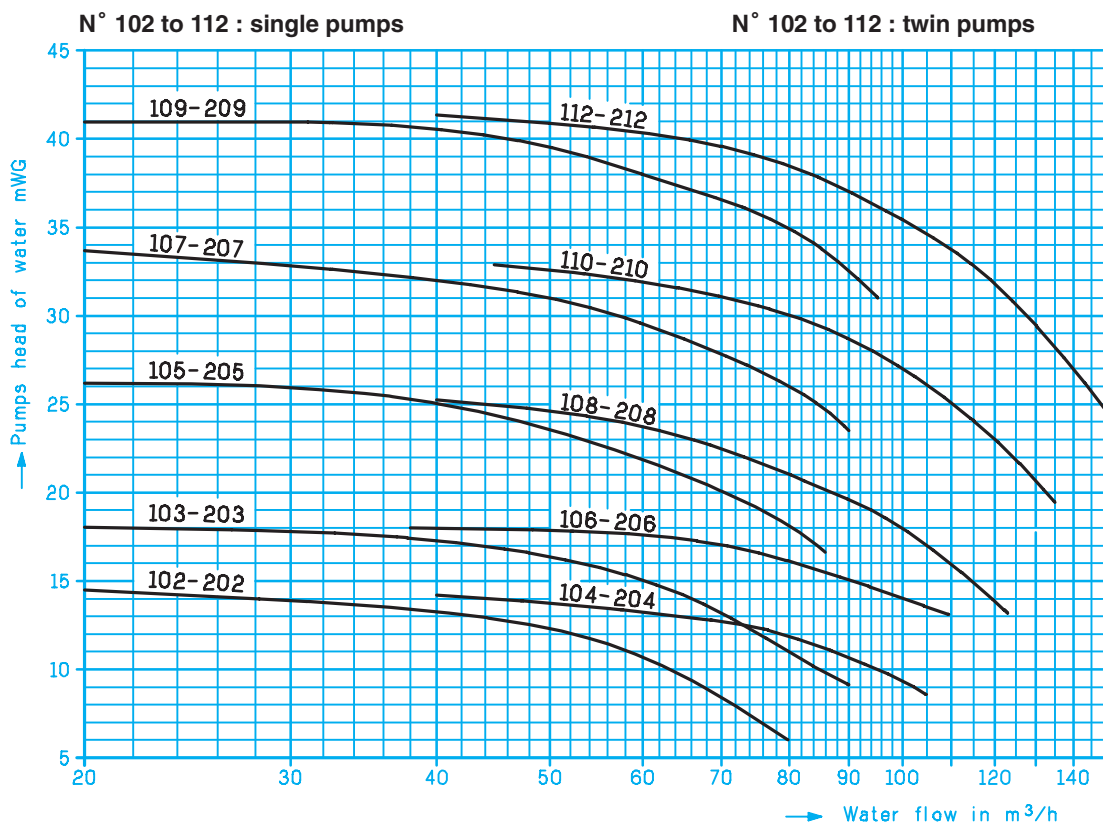

Do not extrapolate above curves. Please respect absolutely minimum and maximum water flow

SOUNDS LEVELS

Standard version - High speed fans

■ Acoustic pressure level ref 2×10^{-5} Pa ± 3 dB (1)

LC - LCH - LCT	SOUND PRESSURE LEVEL SPECTRUM (dB)								Total sound pressure level dB(A)
	63 Hz	125 Hz	250 Hz	500 Hz	1000 Hz	2000 Hz	4000 Hz	8000 Hz	
1203Z	65	63	60	55	54	49	50	50	60
1400Z	66	64	60	55	54	51	53	52	60
1600Z - 1803Z	67	65	62	56	55	51	53	52	61
1804Z	67	65	61	55	54	50	52	51	60
2000Z - 2200Z - 2400Z	67	65	62	56	55	51	53	52	61

■ Acoustic power level ref 10^{-12} W ± 3 dB

LC - LCH - LCT	SOUND POWER LEVEL SPECTRUM (dB)								Total sound power level dB(A)
	63 Hz	125 Hz	250 Hz	500 Hz	1000 Hz	2000 Hz	4000 Hz	8000 Hz	
1203Z	97	95	92	87	96	81	82	82	92
1400Z	98	96	92	87	86	83	85	84	92
1600Z - 1803Z	99	97	94	88	87	83	85	84	93
1804Z	99	97	93	87	86	82	84	83	92
2000Z	99	97	94	88	87	83	85	84	93
2200Z - 2400Z	100	98	95	89	88	84	86	85	94

Low noise version - Low speed fans + compressor phonic insulation

■ Acoustic pressure level ref 2×10^{-5} Pa ± 3 dB (1)

LC - LCH - LCT	PRESSURE LEVEL SPECTRUM (dB)								Total sound pressure level dB(A)
	63 Hz	125 Hz	250 Hz	500 Hz	1000 Hz	2000 Hz	4000 Hz	8000 Hz	
1203Z	62	61	57	52	48	44	42	40	55
1400Z	63	62	57	52	48	46	45	42	55
1600Z - 1803Z	64	63	59	53	49	46	45	42	56
1804Z	64	64	58	52	48	45	44	41	55
2000Z - 2200Z - 2400Z	64	63	59	53	49	46	45	42	56

■ Acoustic power level ref 10^{-12} W ± 3 dB

LC - LCH - LCT	SOUND POWER LEVEL SPECTRUM (dB)								Total sound power level dB(A)
	63 Hz	125 Hz	250 Hz	500 Hz	1000 Hz	2000 Hz	4000 Hz	8000 Hz	
1203Z	94	93	89	84	80	76	74	72	87
1400Z	95	94	89	84	80	78	77	74	87
1600Z - 1803Z	96	95	91	85	81	78	77	74	88
1804Z	96	96	90	84	80	77	76	73	87
2000Z	96	95	91	85	81	78	77	74	88
2200Z - 2400Z	97	96	92	86	82	79	78	75	89

Pressure levels are calculated following ISO 3744 regulation $L_p = L_w - 10 \log S$, in free field and at 10 meters from the unit.

We remind that the acoustic pressure level is given as an indication and that only the sound power level is comparable and certified.

CIAT Air cooled chillers with propeller fans

ciatcooler **LC**

DIMENSIONS

■ CIATCOOLER LC 2, 3 or 4 compressors, 2 refrigerant circuits

PROPELLER FANS

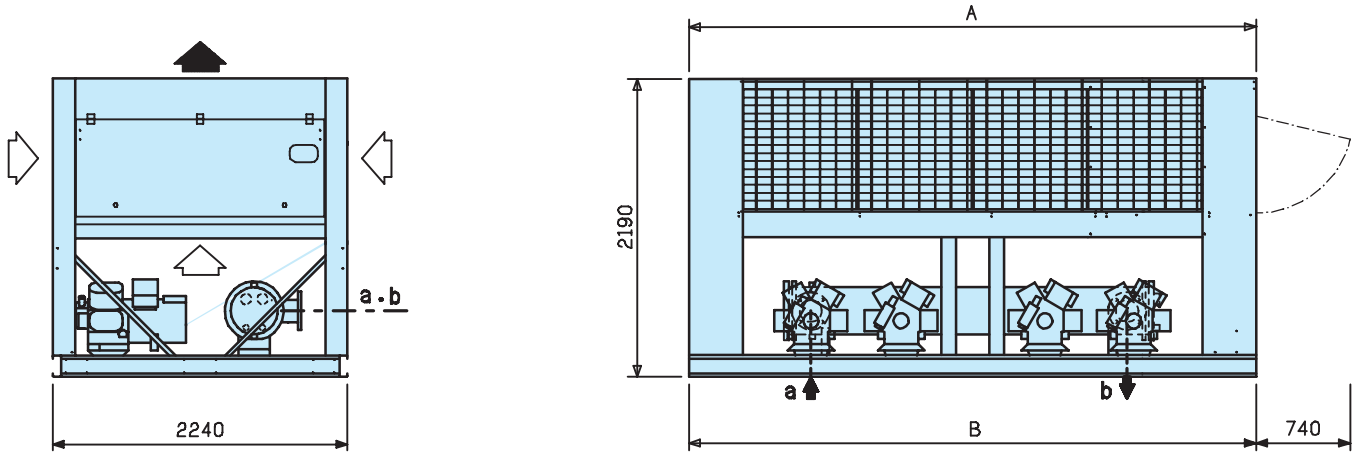

◁ Condenser air inlet
▲ Condenser air outlet

a : Chilled water inlet
b : Chilled water outlet

LC	1203Z	1400Z	1600Z	1803Z	1804Z	2000Z	2200Z	2400Z	
A	3273	3579	4551	4551	4551	4551	5523	5523	
B	3250	3556	4528	4528	4528	4528	5500	5500	
Nb of compressors	2 or 3			3 or 4					
Weight kg	empty	3150	3450	3610	3810	3850	4100	4810	4930
	in operation	3250	3550	3710	3910	4000	4250	4950	5060

■ CIATCOOLER LCH 2, 3 or 4 compressors, 2 refrigerant circuits

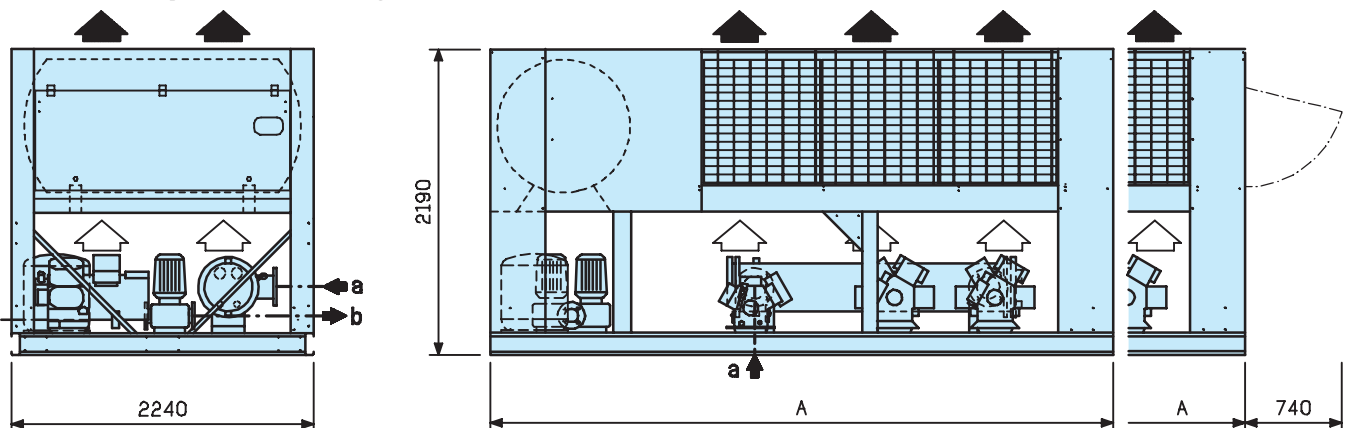

◁ Condenser air inlet
▲ Condenser air outlet

a : Chilled water inlet
b : Chilled water outlet

LCH	1203Z	1400Z	1600Z	1803Z	1804Z	2000Z	2200Z	2400Z	
A	4308	4609	5581	5581	5581	5581	6553	6553	
Weight kg	empty	3350	3830	4000	4210	4410	4660	5370	5490
	in operation	4450	5400	5610	5810	6060	6310	7010	7120

CIAT Air cooled chillers with propeller fans

ciatcooler



DIMENSIONS

■ CIATCOOLER LCT 3 compressors, 2 refrigerant circuits

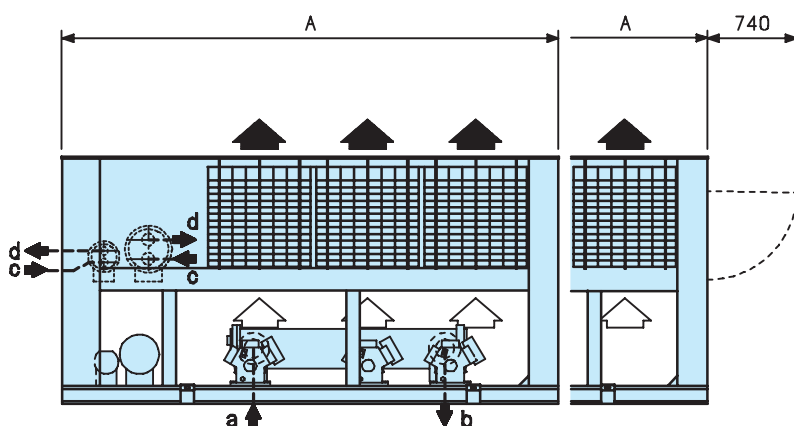
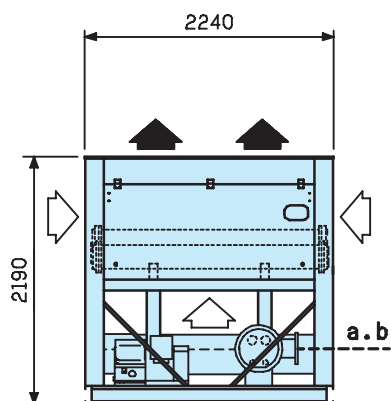

PROPELLER FANS

- Condenser air inlet
- Condenser air outlet

- a : Chilled water inlet
- b : Chilled water outlet

- c : Condenser hot water inlet
- d : Condenser hot water outlet

■ CIATCOOLER LCT 4 compressors, 2 refrigerant circuits

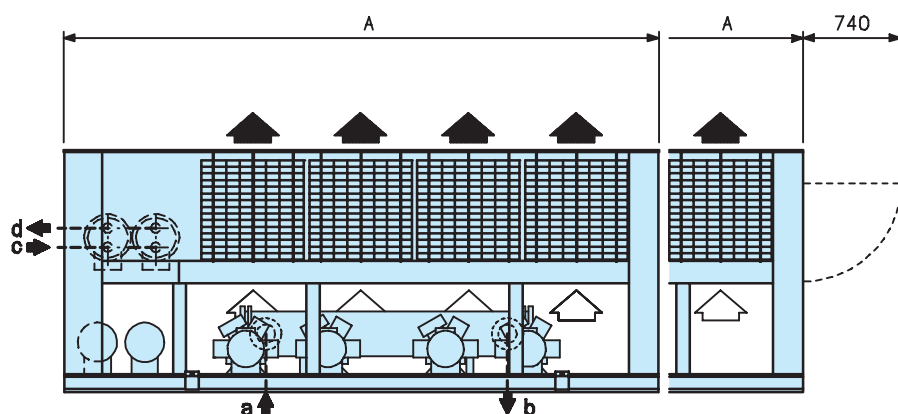
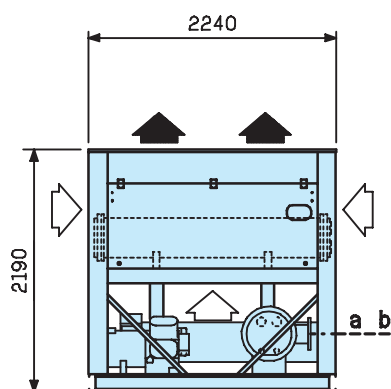

- Condenser air inlet
- Condenser air outlet

- a : Chilled water inlet
- b : Chilled water outlet

- c : Condenser hot water inlet
- d : Condenser hot water outlet

LCT	1203Z	1400Z	1600Z	1803Z	1804Z	2000Z	2200Z	2400Z
A	4303	4609	5581	5581	5581	5581	6553	6553
Weight kg	empty	4020	4060	4560	4710	5000	6100	6400
	in operation	4120	4210	4880	5030	5300	6200	6500

